

Battery Backup Types

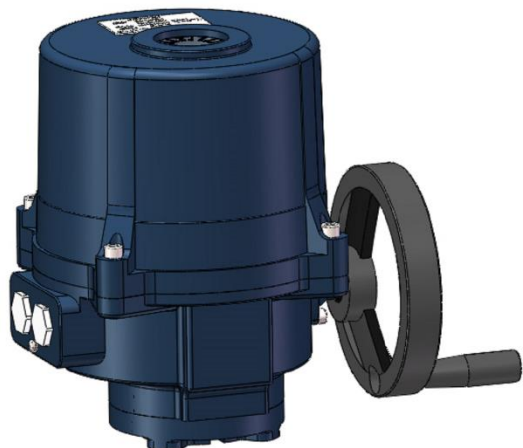

Overview

- 0-360 ° rotation electric industrial service actuators.
- Power supply options: 24VDC、120VAC; Operate on 50Hz or 60Hz supplies.
- Humidity resistance: Can withstand 90% maximum relative humidity(non condensing) .
- Protection Grade: IP 67、Exd IIC T6Gb(TBD)、Ex tb IIIC T80°C Db(TBD)
- Temperature resistance: -4°F~158°F (Customizable -40°F) .
- Seismic capacity: XYZ10g.0.2 ~ 34Hz, 30mins.
- ISO 5211 Mounting base
- Control Mode: Modulating Control/Analog Switch
 - ⊗ Modulating Control: After the product is powered on, use the signal generator to input control signal to control the valve.
 - ⊗ Analog switch: After the product is powered on, connect the corresponding port to Open/Close the valve (Dry connect)
- Function: Battery Backup\Internal Heater
 - ⊗ Battery Backup: When the product is powered off, the valve will automatically return to the set position.
 - ⊗ Internal Heater: used for dehumidification to prevent condensation with in the product.

Specifications

Model No	Torque		Switch Time Sec/90°	Motor Power W	ISO Mounting Base	Rated current(A)		Weight lb	Manual Device
	N.m	In.lbs				24VDC	120VAC		
NTQ/FS	100	885	20	20	F07-F10	1.8	0.4	30.86	Clutchless Hand Wheel
	200	1770	20	40	F07-F10	3.3	0.8	30.86	
	300	2655	20	60	F07-F10	5.2	1.0	30.86	
	450	3983	30	80	F07-F10	6	1.4	30.86	

Materials of Construction

#	DESCRIPTION	MATERIALS
1	IP67 Actuator Housing	aluminum alloy, anodized and coated with polyester powder .
2	Indicator window	Toughened glass
3	Captured Cover Screw	304 stainless steel
4	Manual handwheel	Aluminium alloy
5	IP67 Cover Seal	NBR O-Ring
6	Main Output Gear	40Cr alloy steel

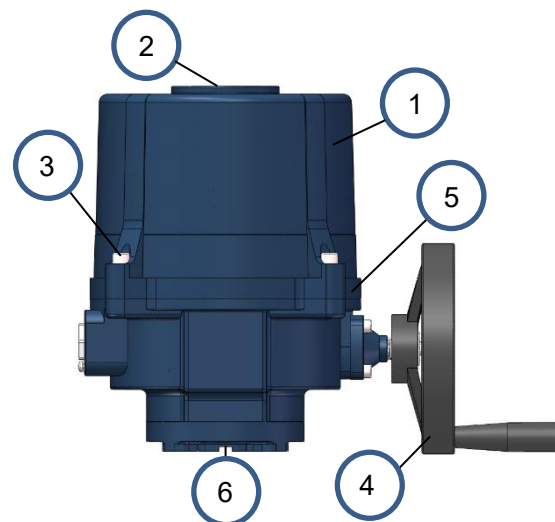

Dimensional Drawing

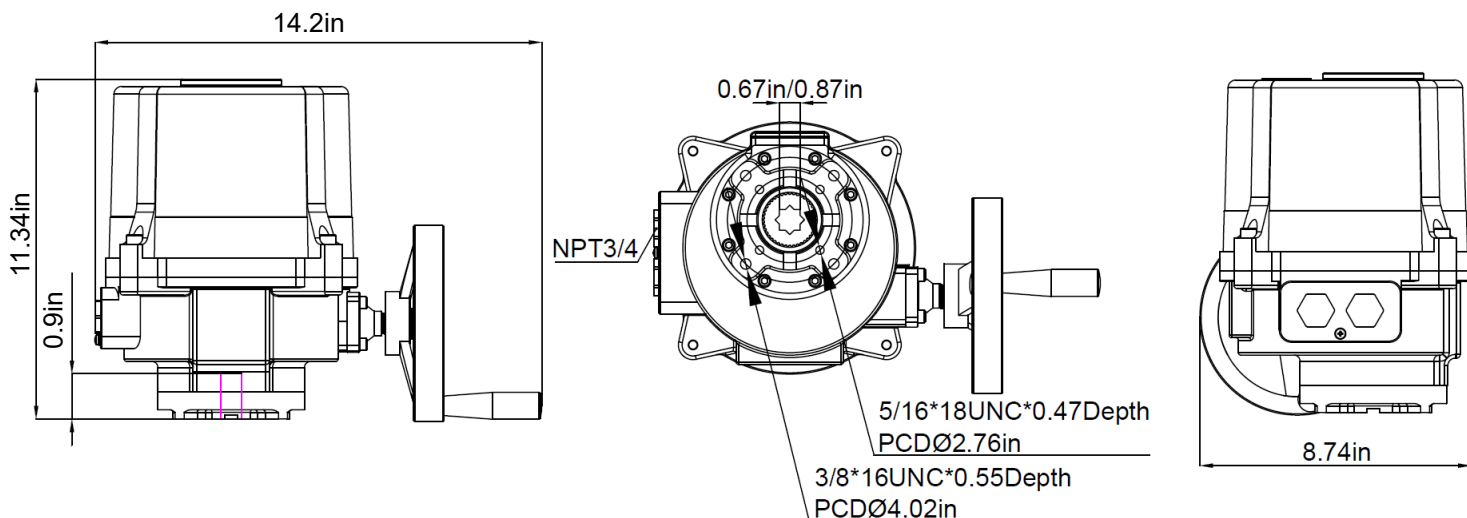

Internal components

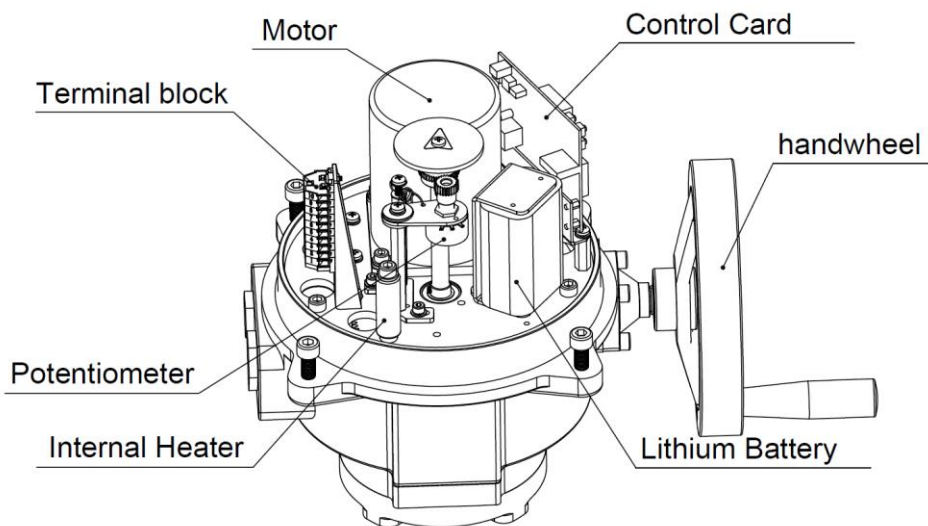

NTQ/FS Battery Backup Modulating Control Types 24VDC

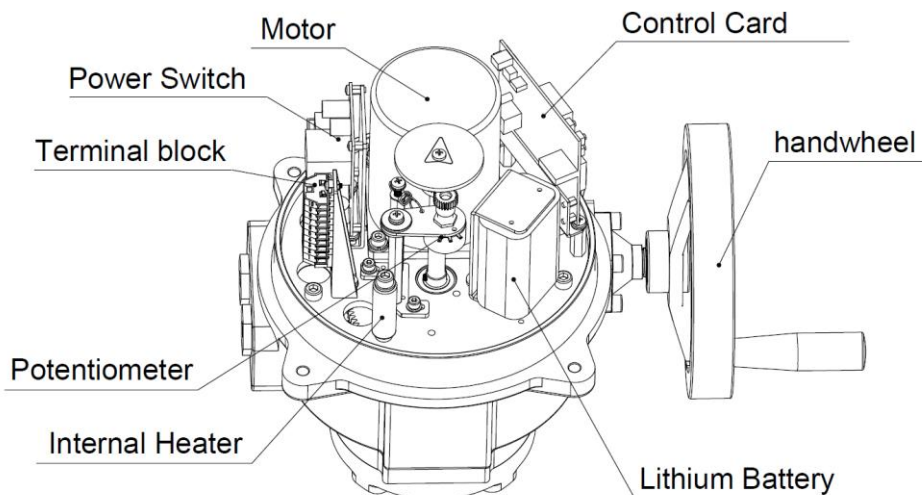

NTQ/FS Battery Backup Modulating Control Types 120VAC

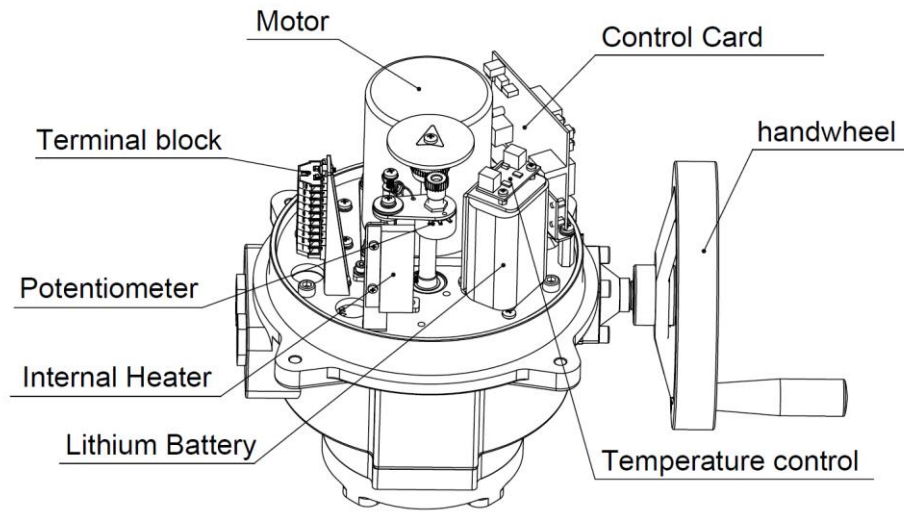

NTQ/FS Battery Backup Modulating Control Types 24VDC (Customizable -40°F)

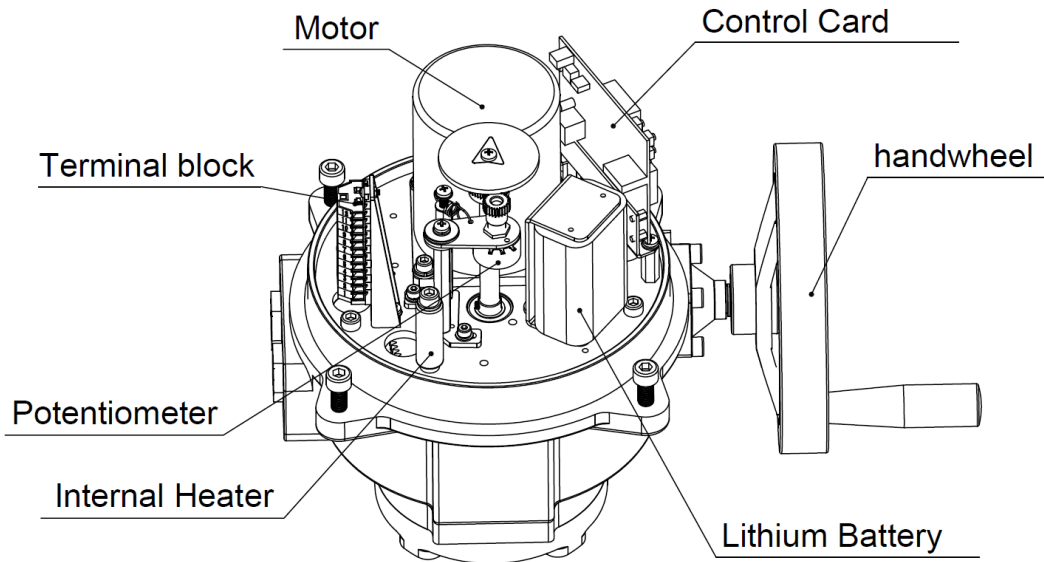

NTQ/FS Battery Backup Analog Switch Types 24VDC

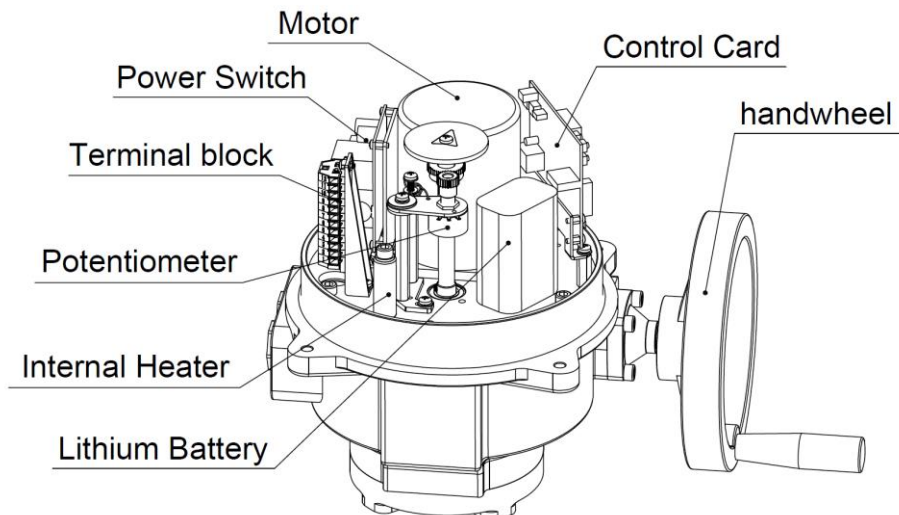

NTQ/FS Battery Backup Analog Switch Types 120VAC

Wiring Diagrams

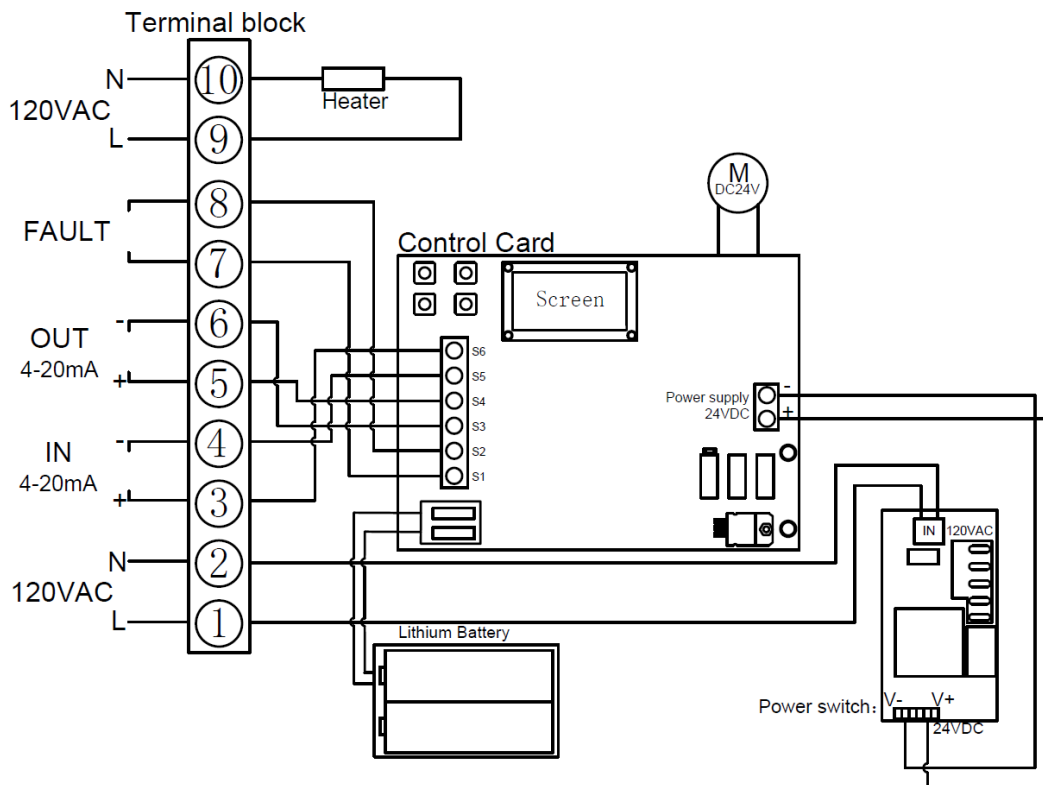

NTQ/FS Battery Backup Modulating Control Types 120VAC

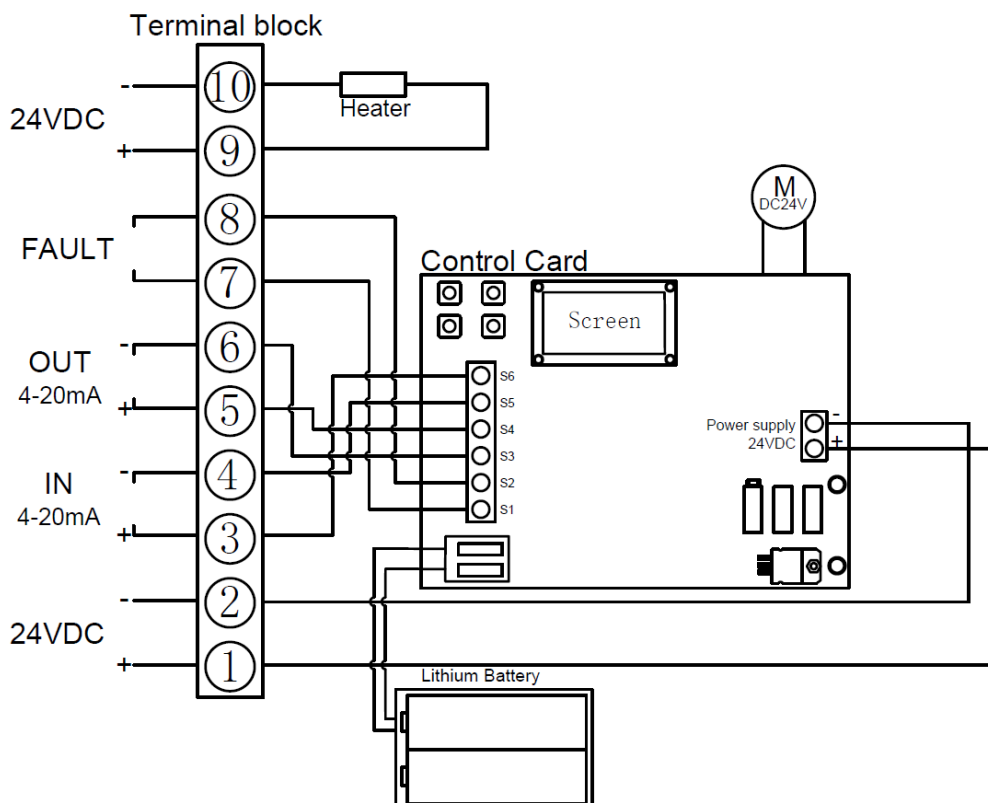

NTQ/FS Battery Backup Modulating Control Types 24VDC

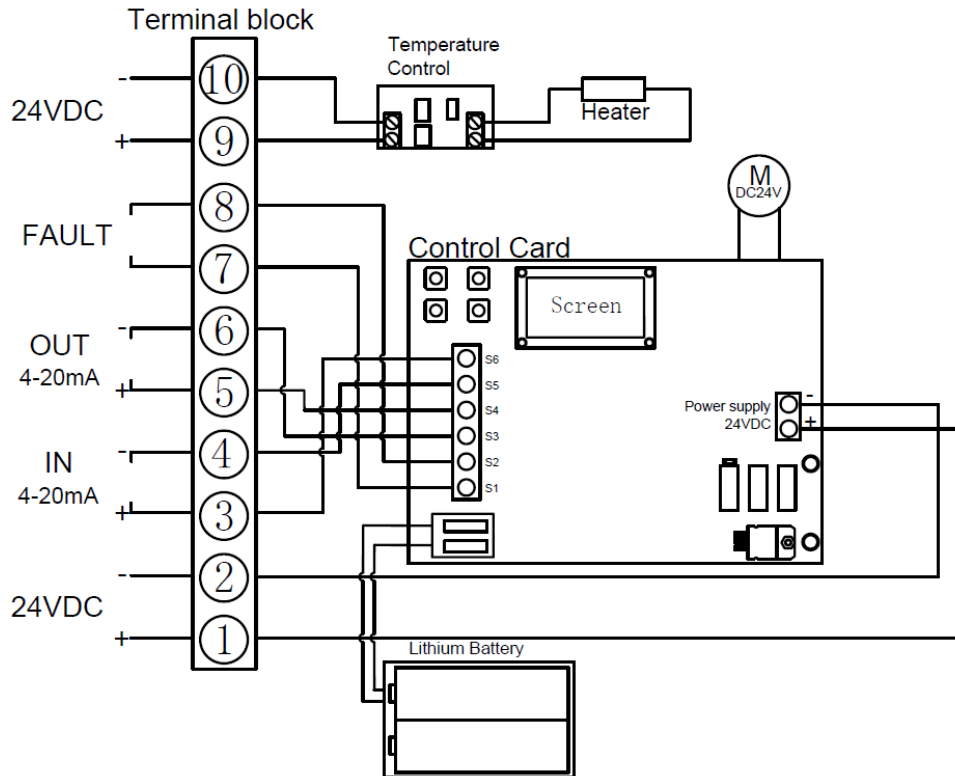

NTQ/FS Battery Backup Modulating Control Types 24VDC (Customizable -40°F)

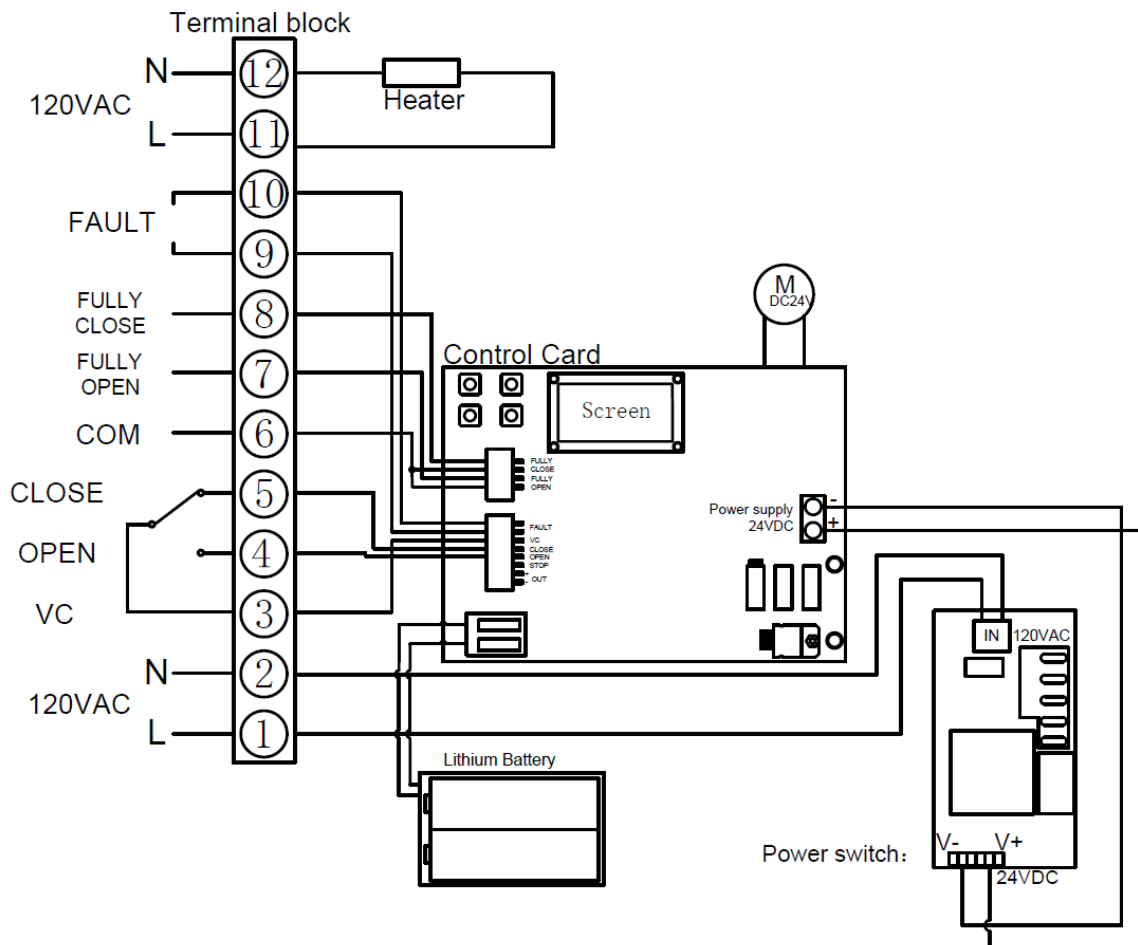

NTQ/FS Battery Backup Analog Switch Types 120VAC

